



PRODUCT DATA SHEET

PAGE 1/1

MS10 Ground element

Item no. MB10050020



TECHNICAL DATA

| | |
|--------------------|--|
| Dimensions: | 100x50x300mm (WxDxH) |
| Material: | Aluminum, anodized E6/EV1 |
| Color: | silver |
| Mounting material: | 4 x Countersunk screw M5x16 A2 4 x Countersunk screw M5x25 A2 |
| Weight: | approx. 0,9kg |

DIMENSIONS

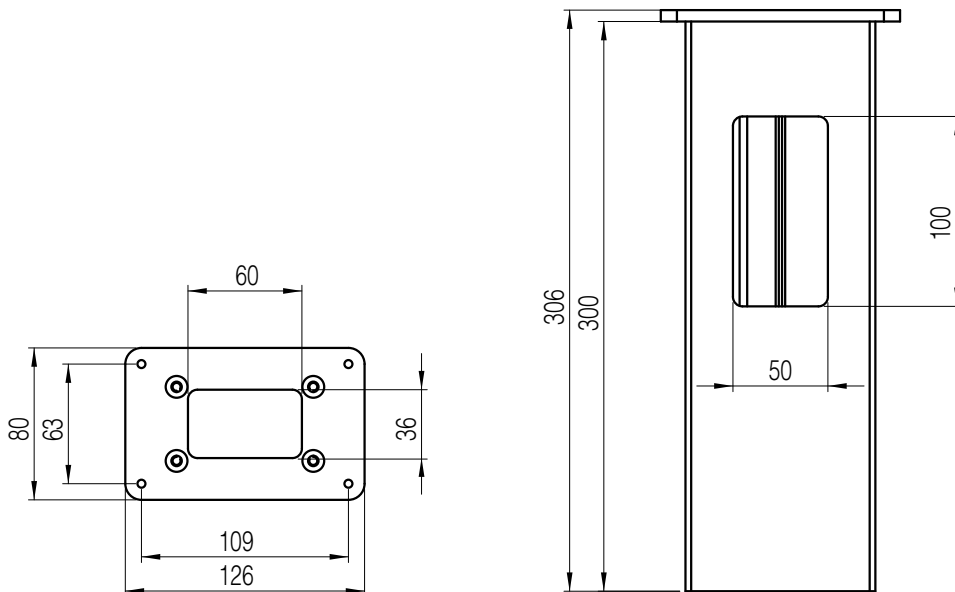

All dimensions in millimeters.